

All dimensions are in inches
VCRS® DIMENSION CHART

GUTTER SIZE	A	B	SUPPLY TUBE SIZE
8 X 10	8	10	3 X 4
8 X 12	8	12	4 X 6
10 X 10	10	10	4 X 6
10 X 12	10	12	4 X 6
12 X 12	12	12	4 X 6

POOL SIZE (WxL) (FT.)		20x40	25x50	30x60	45x75	45x82	60x75	60x82	75x82	45x120	60x120	60x164	75x164			
PERIMETER (FT.)		120	150	180	240	254	270	284	314	330	360	448	478			
SURFACE AREA (SQ. FT.)		800	1250	1800	3375	3690	4500	4920	6150	5400	7200	9840	12300			
FLOW CAPACITY (G.P.M.)	VCRS® GUTTER SIZE	WITH GRATING	1 CONVERTER	8 X 10	542	530	520	500	496	492	487	480	475	470	448	440
				8 X 12	685	670	660	635	630	625	622	612	605	600	573	565
				10 X 10	708	694	680	653	648	642	635	625	621	610	582	574
				10 X 12	921	905	889	860	854	845	840	826	820	809	775	765
				12 X 12	1280	1260	1240	1205	1195	1186	1178	1162	1155	1138	1097	1085
		2 CONVERTERS	8 X 10	1136	1119	1108	1085	1080	1070	1065	1055	1050	1040	1010	1000	
			8 X 12	1420	1410	1395	1365	1360	1350	1345	1335	1328	1318	1285	1270	
			10 X 10	1477	1460	1443	1416	1410	1399	1394	1376	1372	1360	1320	1307	
			10 X 12	1914	1900	1878	1843	1835	1825	1815	1805	1793	1779	1735	1720	
			12 X 12	2645	2620	2600	2560	2550	2536	2528	2510	2497	2475	2420	2410	

- Notes:
- Flow capacities listed above represent maximum gutter capacities.
 - Consult with local authorities to verify gutter design criteria as some codes require design flows greater than the system circulation rate.
 - Supply tube inlets are designed to operate at 8-10 p.s.i. Diameter, quantity, and spacing will vary depending on pool configuration and system flow rate.
 - The above flow capacities are based on properly sized gutter drain converters designed for a velocity no greater than 3 feet per second and gutter systems that extend fully around pool perimeter.
 - A minimum of two gutter drain converters are recommended for pool perimeters of over 300 feet or for pools emphasizing competition swimming.

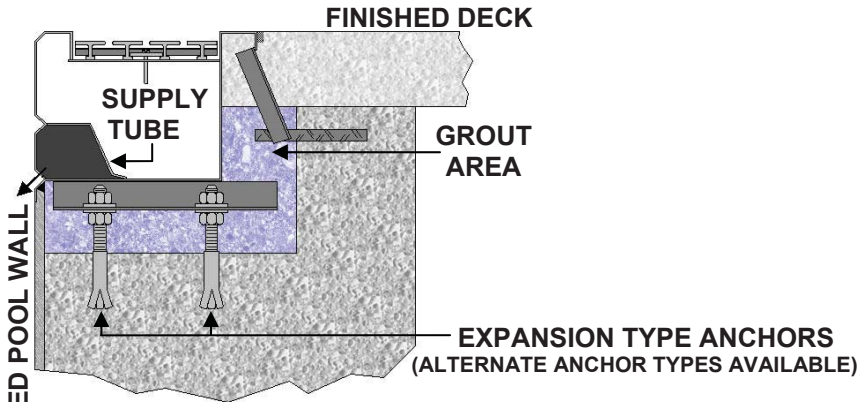

Deck Level

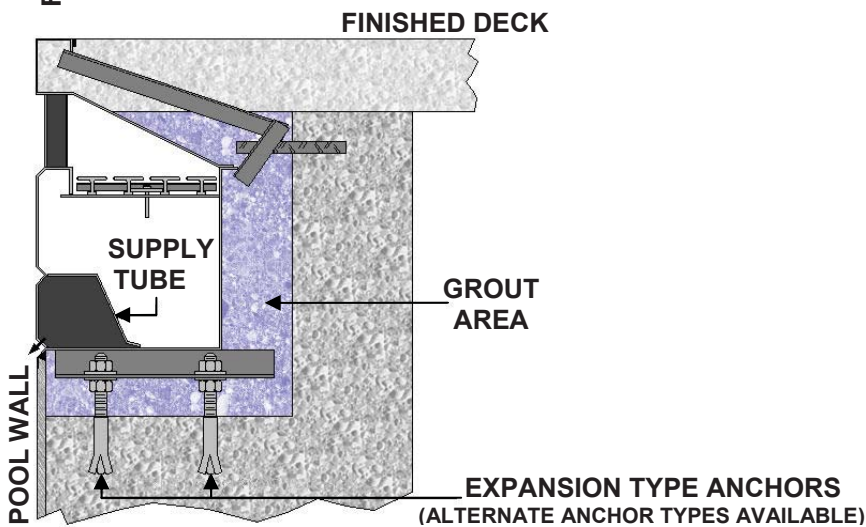

Fully Recessed

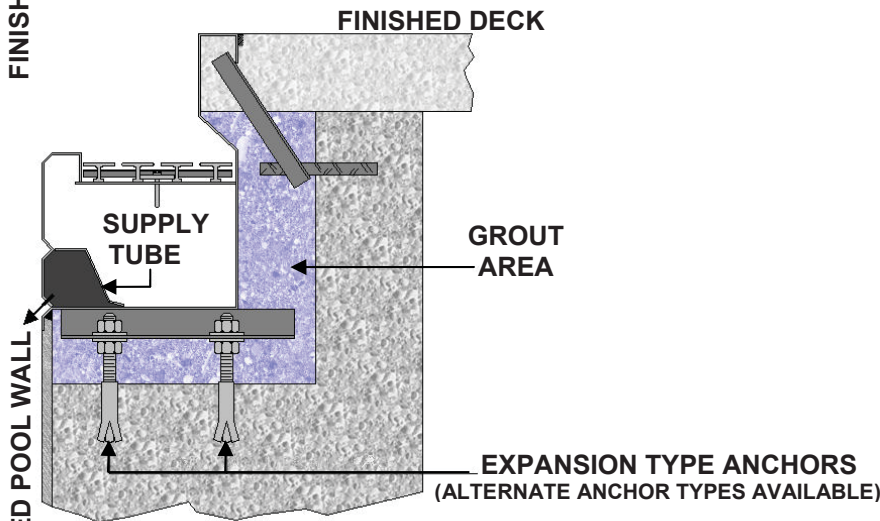

Semi - Recessed

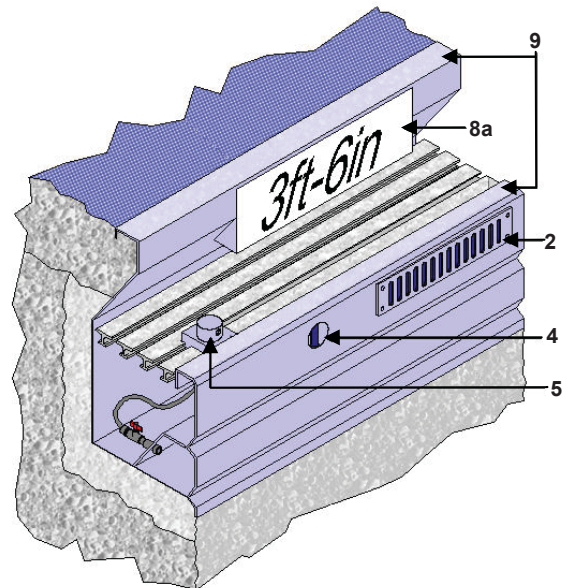
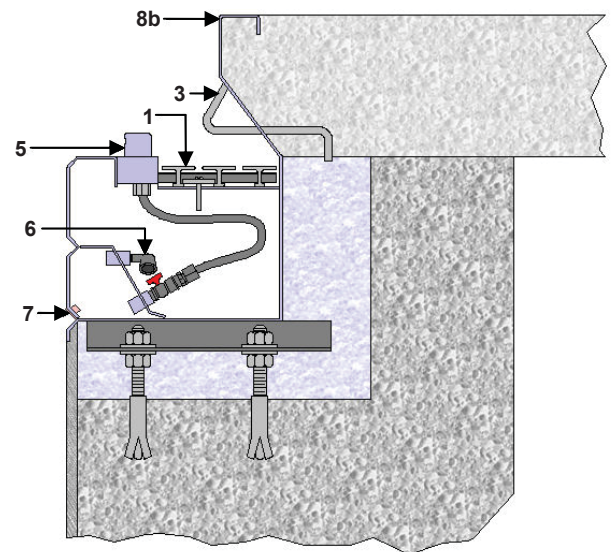

Accessories	
ITEM	DESCRIPTION
1	Fiber composite grating with non-skid surface & U.V. protection
2	Skimmer/Surge weir, 35 or 50 G.P.M.
3	Line Anchor, Z-type
4	Line Anchor, recessed
5	Surface agitator, adjustable
6	Jet wash fitting
7	Jet inlet insert, nylon or bronze
8a	Depth marker plate
8b	Extended gutter face for depth markers
9	Non-Slip finish

SECTION 13151 STAINLESS STEEL RECIRCULATING OGRS, VAS/VCRS VCRS-2A GUTTER SPECIFICATIONS

PART 1 - GENERAL

DESCRIPTION OF WORK

- A. The work under this section shall include the furnishing and installation of a stainless steel perimeter recirculating gutter system. The system shall consist of an overflow channel filtered water supply channel, finished edge, drain converter, supply converter and other accessories as listed.
- B. The manufacturer shall guarantee the gutter system for a period of 5 years for materials and workmanship if the system is operated in accordance with written instructions. The fiberglass grating included with the system shall carry the original manufacturer's warranty is for a period of one (1) year.

BASE BID REQUIREMENT

- A. The method of water recirculating specified and shown on the drawings is intended as the basis for receiving bids and is the preference of the owner and architect. The base bid proposal shall include the gutter system as specified by Neptune-Benson, Inc. of Coventry, Rhode Island.

PERFORMANCE REQUIREMENTS

- A. It is the intent of the specifications that the swimming pool perimeter gutter system channel flow and surface cleaning be maintained under all conditions of operation and that no water be discharged to waste except when backwashing the filters or emptying the pool.
- B. The gutter system shall be sized to accommodate a flow capacity equal to 100% of the pool system recirculation rate.
- C. The system shall include a handhold at the overflow lip and required anchors for racing and/or safety lines.

SUBMITTALS

- A. Provide detailed shop drawings for the gutter system installation including; anchor details and layout, section layout, corner details, line anchor detail and layout, grating detail and grate support layout, converter details and converter locations, converter concrete blockout dimensions and requirements.
- B. Upon request, provide detailed hydraulic calculations showing the gutter channel flow capacity.

FINISHED EDGE

- A. The bottom front edge of the gutter shall incorporate a flange extending 1" below the bottom of the gutter channel and form a second "V" notch. It shall be flush with the face of the gutter and pool wall finish as shown on the drawings. Systems not incorporating a finished edge on the gutter shall not be acceptable.

PART 2 - PRODUCTS

MATERIALS

- A. The exposed surface of all stainless steel shall be fabricated of type 304L, with a number 3 polished finish. The anchor angles and stiffeners shall be type 304 stainless steel. All components of the system shall be no less than 12 gauge in thickness.

CHANNEL

- A. The OGRS gutter channel shall be fabricated according to the dimensions detailed on the drawings.

-OR-

- A. The VAS/VCRS gutter channel shall be fabricated according to the dimensions detailed on the drawings. The face of the gutter shall incorporate a "V" notch. The upper portion of the filtered water supply tube shall be welded to the inside of the "V". There shall not be any horizontal welding distortion noticeable on the face of the gutter. Systems not incorporating a "V" notch on the gutter face shall not be acceptable.

-OR-

- A. The VCRS-2A gutter channel shall be fabricated according to the dimensions detailed on the drawings. The gutter shall be a two component channel, an upper channel and a lower channel. The channels shall be evacuated by a gutter convertor, installed where indicated on the plans. The upper channel shall also evacuate to the lower channel at 15 foot intervals around the perimeter of the pool by means of drainage ports located at the bottom of the upper channel. The face of the gutter shall incorporate a "V" notch. The upper portion of the filtered water supply tube shall be welded to the inside of the "V". There shall not be any horizontal welding distortion noticeable on the face of the gutter. Systems not incorporating a "V" notch on the gutter face shall not be acceptable.
- B. The gutter system shall be sized to accommodate a flow capacity equal to 100% of the pool system recirculation rate.

SUPPLY TUBE/FILTERED WATER INLETS

- A. The filtered water supply shall be TIG welded stainless steel, with inlet nozzles spaced not more than 42" on center around the perimeter of the pool. The quantity of inlets shall be determined to

deliver the required flowrate. The inlets shall be spaced so as to not interfere with wall areas, electronic touch pads or competitive racing lanes.

SURFACE SKIMMING

- A. Surface skimming shall be continuous around the entire pool perimeter. The water level of the pool shall be maintained at $\pm 1/16$ " above the overflow lip of the gutter. Dynamic surge action shall be quelled by the gutter channel to reduce repelling back onto the swimming surface.

WEIRS

- A. The system specified shall provide in pool surge capacity of one gallon per square foot of surface area and surface cleaning at quiescent times by means of integral surge weirs. These weirs shall permit water displaced by bathers and their surge to remain in the pool body.

GRATING

- A. The gutter channel shall be covered with a pultruded glass fiber composite grating. The grating shall be white, non-skid and UV coated. The style shall be T bars at 2" centers with cross rods at 12" centers.
- B. The grating shall be fastened to the support angles with non-corrosive hardware.
- C. The grating support angles shall be T304L stainless steel and shall be spaced not more than 36" on center around the entire pool perimeter.

CONVERTERS

- A. Gutter drain and supply/return converters shall be sized according to the system requirements and installed in the system where indicated on the drawings.
- B. The drain converter shall be fabricated of T304L stainless steel no less than 12 ga in thickness. The supply (pressure) converter shall be fabricated of T304L stainless steel no less than 10 ga thickness. A 1" x 1" x 1/8" angle shall be welded around the converter to increase rigidity.

NOTE: For buried applications the supply converter must be completely encased in 4" minimum of concrete or grout.

- C. All converters shall be fitted with slotted flanged connections. Other means of connection to perimeter piping shall not be acceptable.

NON-SKID SURFACES

- A. The horizontal surfaces of the gutter are to have a skid resistant surface.

EXPANSION ANCHORS

- A. The entire gutter channel shall be anchored to the pool walls with non-corrosive anchors drilled into the pool beam at no less than 48" on center around the pool perimeter.
- B. The anchors shall be zinc plated expansion type with stainless steel threaded rods. 1.5" x 1.5" 10 gauge stainless steel slotted angles shall be secured to the threaded rods with fasteners to provide accurate leveling.
- C. The rear top gutter edge shall be aligned and secured to the pool beam with 12 gauge stainless steel support angles. The angles shall be welded to anchor pins installed in the pool beam at no less than 48" on center around the entire pool perimeter.

PARAPET ENDWALLS

- A. The endwall sections of the gutter shall incorporate a fully recessed parapet profile and shall consist of 2" x 2" stainless steel square tubing flush with top of gutter deflector and gutter face. 4" x 4" stainless steel racing line anchors shall support the square tubing as shown on the drawings. Fiberglass grating shall extend from the tubing to the top of the gutter deflector creating a surface level to the pool deck. Grating and support angles shall be as previously described in these specifications.

DEPTH MARKERS

- A. The contractor shall provide self-adhesive black vinyl depth markers as detailed on the plans and the contractor shall apply these after all concrete work is complete.

JET WASH FITTINGS

- A. The channel shall be fitted with jet wash spray nozzles as detailed on the plans to provide a constant flow of filtered water to the gutter system.

RECESSED ANCHORS

- A. All racing lane and safety line anchors shall be included as detailed on the drawings. Anchors shall be integral to the gutter system and recessed not to protrude above any finish face of the gutter

Z-HOOK ANCHORS

- A. A stainless steel Z-hook shall be provided for anchoring racing lanes and safety lines at the locations indicated on the drawings.

SURFACE AGITATOR

- A. A surface agitator shall be installed at each diving board location and shall include a spray nozzle, valve and connecting tube. The assembly shall be installed to allow easy access from the deck immediately adjacent to the diving board.

STEP COVER

- A. A stainless steel step cover shall be installed at each step location as detailed in the drawings

RECESSED STEP SUB-ASSEMBLIES

- A. Recessed steps shall be constructed of T304 14 gauge stainless steel.
- B. Sub-assemblies shall be constructed of 1 ½" x 1/8" stainless steel.
- C. Assemblies shall be welded to the underside of the perimeter stainless steel gutter.
- D. Quantity and locations per plan.

DECK DRAIN

- A. A separate deck drain collection tube shall be attached to the gutter system where the deck meets the top edge of the back plate. This tube shall have connections to onsite waste lines as detailed on drawings there shall be clean-out ports located as shown.

PART 3 - EXECUTION

INSTALLATION

- A. All components of the system including anchor plates, gutter channel, supply tube, converters, grating and line anchors; shall be installed by personnel approved by the manufacturer.
- B. Welding shall be performed by a welder with at least five (5) years experience in the welding of stainless steel gutters.
- C. Expansion anchors shall be installed by the gutter installer and shall be spaced no more than 48" on center and at the elevation shown on the drawings.
- D. The fabricated gutter components shall be delivered to the jobsite, unloaded by the pool construction contractor and stored in the shallow end of the pool.
- E. All other installation work and required installation materials, including scaffold brackets and scaffolding, shall be provided and performed by the gutter manufacturer's installation crew. All scaffolding shall conform to OSHA requirements where applicable.
- F. The gutter system shall be installed level within a tolerance of $\pm 1/16"$.

WELDS

- A. All seams shall be welded by the TIG process and shall result in a uniform appearance. Welds shall not be ground. All welds shall be brushed after cooling to approximately 300 degrees. Filler metal shall be added to present a flush appearance to finished seams.
- B. All horizontal welds shall be fully accessible for inspection.

TESTING VERIFICATION

- A. After the gutter system has been fully welded, anchored and secured, the supply tube shall be air pressure tested at 12 psi for 2 hours.
- B. After the test has been satisfactorily completed, the inlets shall be drilled.
- C. Factory drilled inlets or factory tested supply tubes shall not be acceptable.
- D. Final gutter installation is to be approved by a factory authorized engineer.

GROUTING

- A. After the gutter system has been installed, the contractor shall place a non-metallic, non-shrink grout underneath and behind the gutter to completely encase the channel.
- B. The grout material shall include Sika Interplast-N as manufactured by Sika Corp. Mixing proportions shall be in accordance with Sika Corp. guidelines.

CAULKING – SEALANT

- A. After the gutter system has been installed, the contractor shall place a sealant under the finished edge and behind the deck strip as shown on the drawings.
- B. The sealant shall be a two part Elastomeric Polysulfide based joint seal. P/G primer is required for joints subjected to hydrostatic pressure or submersion.

CLEANING/PASSIVATION

- A. The stainless steel components shall be cleaned as required to present a uniform appearance.
- B. Blending of the surface shall be done with a 3M pad #7447, or 100 grit abrasive. (NOTE: frictional rubbing parallel with material grain only)
- C. The strength of the welds shall not be reduced by grinding.

D. At the completion of the gutter system installation, the gutter installer shall clean and passivate all accessible gutter and welds, including below the grating, with either a Citric or nitric acid solution per manufacturer's cleaning instructions.

CERTIFICATION

A. Final gutter installation is to be certified by a factory authorized licensed engineer.

WARRANTIES

The manufacturer shall guarantee the gutter system for a period of 5 years for materials and workmanship if the system is operated in accordance with written instructions. The fiberglass grating include with the system shall carry the original manufacturer's warranty for a period of one (1) year.