

## Hellbender® Whitewater Systems (WWS) provide superior performance for Dissolved Air Flotation Systems

Dissolved Air Flotation systems are designed to remove contaminants such as total suspended solids (TSS), biochemical oxygen demand (BOD), and oils and greases (O&G) from wastewater. Contaminants are removed using a dissolved air-in-water solution, or “whitewater” produced by injecting air under pressure into a recycle stream that is a portion of clarified DAF effluent. This recycle stream is then combined and mixed with incoming wastewater in an internal contact chamber where the dissolved air comes out of solution in the form of tiny microbubbles that attach to the contaminants, rise to the surface and form a floating layer of material that is removed by a surface skimmer.

Improper design of a whitewater system can result in poor DAF performance. Some of the tell-tale signs of an inefficient whitewater system include:

- Whitewater should visually have a “milky white” or opaque appearance with small microbubbles barely visible to the eye.
- Large bubbles and/or turbulence in the DAF contact chamber. Large bubbles rise too fast, which can create turbulence and shear or break up the floc.
- High recycle flow rates to compensate for poor air solubility which increases the hydraulic loading on the DAF unit.
- Poor effluent quality or high pretreatment chemical costs to compensate for inadequate Whitewater.

Proper design and generation of whitewater is key to the successful performance and efficiency of a dissolved air flotation (DAF) system.

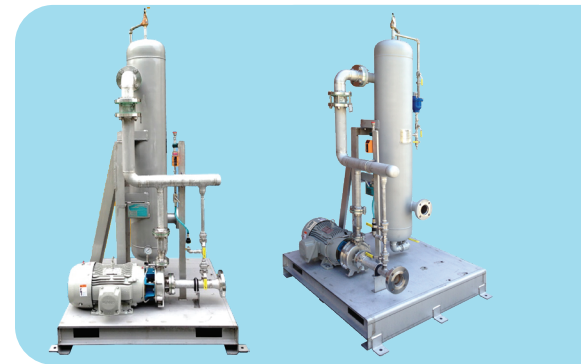
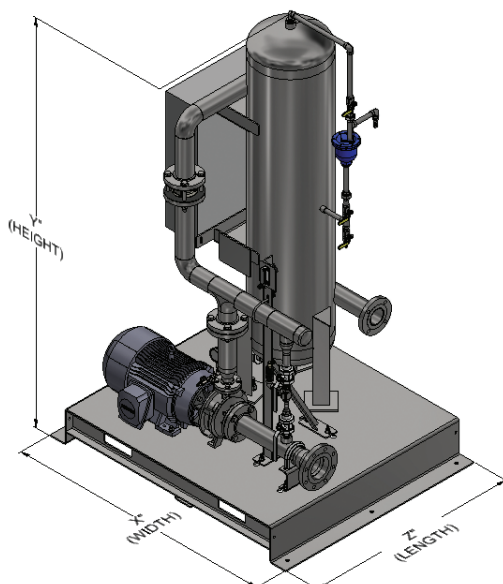

### HOW IS THE HELLBENDER DAF PUMP DIFFERENT FROM A REGULAR CENTRIFUGAL PUMP?

- Specially designed to pump water with entrained air at high pressure (~100psi) without cavitating
- Capable of achieving 100% of theoretical air-in-water saturation
- Higher air dissolving efficiency vs. standard centrifugal pumps due to high pressure and unique design
- Efficiently shears incoming air into very fine bubbles, allowing large amounts of air to be entrained in the water for superior whitewater production

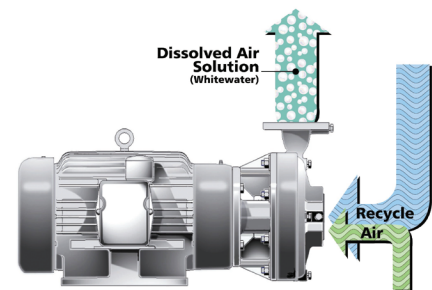

### PRODUCT SPECIFICATIONS

Model Number	WWS-60	WWS-90	WWS-150	WWS-250	WWS-400
Length-Y (in)	43	43	48	50	54
Width- X (in)	56	56	60	66	66
Height-Z (in)	89	89	91	115	116
Estimate Shipping Weight (lbs.)	1,190	1,190	1,390	1,660	2,080

## HELLBENDER® WHITEWATER SYSTEMS

The former Environmental Treatment Systems company had developed standard Hellbender Whitewater Systems (WWS) specially designed to upgrade most existing dissolved air flotation (DAF) systems. The Hellbender WWS is designed to either be a stand-alone system or it can be easily retrofitted to an existing DAF previously fitted with an underperforming whitewater system. These systems can also be added to existing gravity settlers/skimmers to provide whitewater to aid in separation. The system is provided in a pre-engineered skidded design to minimize installation and start-up costs. They are fully tested at the factory and only require simple utility connections (water inlet, water outlet, drains and power).

At the heart of the Hellbender WWS is our innovative and proprietary Hellbender recycle pump specially designed to introduce air into the pump by an eductor loop where the entrained air is quickly dissolved into the water at high pressure (approximately 100 psig) resulting in higher air saturation efficiencies. The system uses ambient air and does not require a compressed air supply.

Hellbender recycle pumps deliver superior whitewater to optimize DAF performance compared to traditional systems that use lower pressure (50-60 psig) pumps and require a separate compressed air supply.

## HELLBENDER WWS CONFIGURATIONS

Standardized Hellbender Whitewater Systems are available in 5 different model configurations with flexible trim packages to suit customer requirements:

- Standard Sizes range from 60, 90, 150, 250, and 400 gpm based on DAF recycle flow rates
- Flexible standard options including:
- 304 or 316L stainless steel piping
  - Economy (Base) instrumentation package with analog gauges
  - Plus instrumentation package includes a recycle flow meter
  - Deluxe instrumentation package includes a recycle flow meter, pressure transmitter, and an air flow sensor
- Skid mounted control panel for easy system integration to existing DAF units

## HELLBENDER WWS ORDERING CODES

Catalog Number:		WWS	O60	A	E	P	D
<b>WWS</b>	<b>Hellbender Whitewater Systems</b>						
<b>Recycle Flow Rate</b>							
060	DAF Recycle Flow Rate (60GPM)						
090	DAF Recycle Flow Rate (90GPM)						
150	DAF Recycle Flow Rate (150GPM)						
250	DAF Recycle Flow Rate (250GPM)						
400	DAF Recycle Flow Rate (400GPM)						
<b>WWS Piping Materials</b>							
A	304 SST Process Piping						
B	316L SST Process Piping						
<b>Instrumentation</b>							
E	Economy Base Model instrumentation (analog gauges, air rotameter)						
P	Plus Model includes Recycle Flow Meter (mag)						
D	Deluxe Model Instrumentation (mag flow meter, pressure transmitter, air flow sensor)						
<b>Control Panel</b>							
P	WWS skid mounted Control Panel (includes Motor soft start)						
N	Without Control Panel and Motor Starter (customers supplied)						
<b>Voltage Options</b>							
D	460 VAC 3Ph 60 HZ						
E	575 VAC 3Ph 60 HZ						

Note: For non-standard options, contact Evoqua Water Technologies Applications Engineering.



210 Sixth Avenue, Suite 3300, Pittsburgh PA 15222 USA

+1-724-772-004 [evoqua.com](http://evoqua.com)

Environmental Treatment Systems and Hellbender are trademarks of Evoqua Water Technologies LLC, its subsidiaries in some countries, and its affiliates. All information presented herein is believed reliable and in accordance with accepted engineering practices. Evoqua makes no warranties as to the completeness of this information. Users are responsible for evaluating individual product suitability for specific applications. Evoqua assumes no liability whatsoever for any special, indirect or consequential damages arising from the sale, resale or misuse of its products.

Front: photo of Hellbender pump systems

© 2021 Evoqua Water Technologies LLC Subject to change without notice IW-HLBNWWS-DS-0121